

DIGITAL INTERNAL THREAD CREST DIAMETER MEASURING INSTRUMENT

MEET INTERNATIONAL
STANDARD API5B



2247-5

- Measure the crest diameter of internal thread with nominal diameter larger than 2 3/8" (60.325mm) and less than 5 1/2" (139.7mm)
- Optional accessory: data output cable (code 7315-50M, 7302-40M, 7305-40M), height standard and zero standard block (code 2237-G□□□, 2237-K□□□)

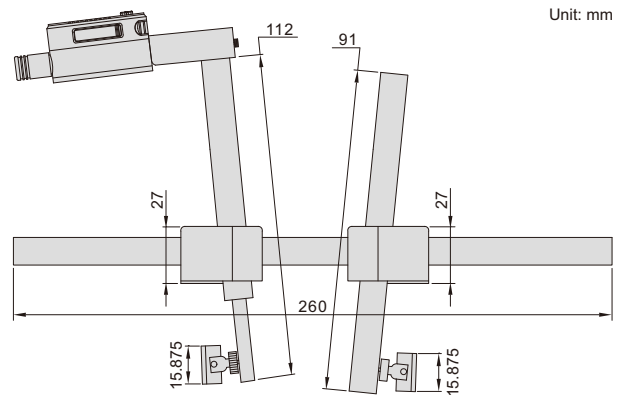

application

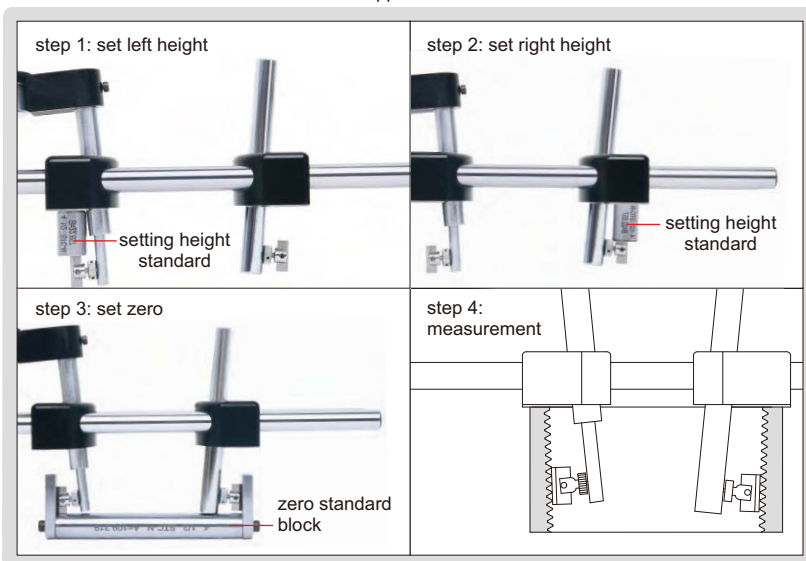

| Code | Range | Digital indicator stroke | Resolution | Accuracy |
|--------|-----------------------------|--------------------------|----------------|----------|
| 2247-5 | 2 3/8-5 1/2"/60.325-139.7mm | 0.2"/5mm | 0.0005"/0.01mm | 0.02mm |